



NEW HOLLAND

E225_{BSR}

E235_{BSR}

NEW HOLLAND KOBELCO



	E225BSR	E235BSR
NET FLYWHEEL POWER	118 kW - 158 hp	
MAX OPERATING WEIGHT	23 400 kg	26 400 kg
BUCKET CAPACITY	0.51 - 0.80 m ³	0.50 - 0.95 m ³



BUILT AROUND YOU

E225BSR/E235BSR

TOP PERFORMANCES PACKED IN COMPACT MACHINES

The new E225BSR and E235BSR are examples of the latest Short Radius advanced technology.

The E225BSR has been designed to satisfy customer needs, provide higher performance in terms of stability and productivity.

The new SR models feature the revolutionary iNDR system that dramatically reduces machine noise level.

Customers appreciate all the E225BSR and E235BSR features and benefits where space and noise are constraints, like urban job-sites and road construction sites.

* A product of the global alliance between New Holland and KOBELCO



* THE PERFORMANCE

C.P.B. (Continuous Power Boost)

Continuous Power Boost is a feature of excellence of both E225BSR and E235BSR. Continuous Power Boost means that, if the operator is facing a very tough application, he can select this function (hydraulic pressure raises to 37.8 Mpa) **with no time limit**. Continuous Power Boost allows him to work problem free on the job-site providing productivity and machine reliability.
A unique feature only offered by New Holland.

NEW “iNDR” (integrated Noise & Dust reduction) cooling system

NEW environmentally friendly Common Rail engine

NEW Triple Articulation Version for E235BSR

NEW Flow & Pressure set-up system

NEW generation hydraulic pumps

NEW operator compartment

NEW hydraulic circuit



E225BSR/E235BSR

INCREDIBLY QUIET
EFFECTIVE DUST PROTECTION
REMARKABLY EASY MAINTENANCE



“Ultimate” - Low Noise Level
95dB(A)

RESEARCH & INNOVATION

New Holland is proud to introduce, the unique and innovative **iNDR (integrated Noise & Dust reduction) Cooling System**, with the engine compartment placed inside a single duct that connects the air intake and the exhaust outlet which are offset.

The design itself, together with a correct positioning of the insulation material inside the duct, minimise the engine noise.

A SIMPLE SOLUTION GRANTS MANY ADVANTAGES

iNDR is a highly environmentally friendly solution to maximise operator comfort and allow work in urban areas with minimum disturbance for inhabitants.

Moreover the ultra cleaned air granted by **iNDR** contributes to a perfect diesel combustion for increased engine performances and reduced fuel consumption and pollution.

INNOVATION & LEADERSHIP

E235BSR: TRIPLE ARTICULATION VERSION

To further enhance the correspondence of **SR** and **Standard** machine projects, New Holland now offers the E235BSR in the **Triple Articulation** version. A version requested in many Markets and chosen by many Customers.

A flexible, productive, modern version orientated to Market demand and Customer satisfaction.

NEW HOLLAND REDEFINE SR CONCEPT

New Holland is proud to reinforce its field leadership by redefining the SR concept, being able to incorporate in compact designs, performances and features of standard models.

As a matter of fact the new SR machines boast a list of superior features and superb performances, all packed in the rounded and compact shape of these new Short Radius machines.

Low noise, high operator comfort and efficiency, superior productivity with reduced risk of machine damages for low operating costs.

DOZER BLADE

E225BSR and E235BSR can be equipped, on request, with a dozer blade.

A useful tool which enhances the excavator's flexibility allowing a variety of jobs with the same machine.

E225BSR can be equipped with 2800 mm or 2990 mm wide blades according to shoes width and machine version.

The 2990 mm wide blade can also be mounted on E235BSR, NLC version, fitted with 600 mm shoes.

Enhanced machines flexibility in refilling ditches, to minimise working time and to increase return of investment.



E225BSR/E235BSR

NEW COMMON RAIL ENGINE



This new generation HINO **Common Rail** engine represents "state of the art" technology, designed to increase performance and production whilst reducing fuel consumption and pollution.

The Common Rail system guarantees that fuel is injected into the cylinders at very high pressure, thus optimising its nebulisation and its mix with an increased quantity of turbocharged and after cooled air. Moreover, the quantity of fuel introduced into the cylinders is electronically controlled so that the "right quantity" is injected at the "right moment" and combined with extra fresh air to provide peak efficiency output from the engine, whilst reducing fuel consumption and emissions of dangerous pollutants. At the same time, noise is also considerably lowered.

A new, durable, efficient, comfortable and economic engine which contributes to reduced operating costs and increased profits.

NEW HYDRAULIC CIRCUIT

EFFICIENCY AND CONTROL

To obtain a Hydraulic Circuit which is much more efficient, controllable, fast, powerful and which consumes less fuel than previous one, New Holland has been working on almost all components. Starting from the state-of-the-art, latest generation, low noise pump to the redesigned control valve with added second arm spool, high swing output torque and new working mode selection functions. All these improvements, combined with rigorous inspections to drastically reduce pressure loss in the whole Circuit, result in smooth and precise movements, better machine control especially on operations that require combined movements.

These outstanding characteristics are further enhanced by the new **H.A.O.A. Control**.

H.A.O.A. (Hydrotronic Active Operation Aid)

Hydrotronic Active Operation Aid is the most effective available combination of an extremely advanced electronic technology that provides a "just in time" comprehensive control of all machine functions, and a deeply refined and sophisticated hydraulic system.

H.A.O.A. continuously optimises hydraulic output according to operator and job demand, providing the best machine controllability, productivity, operator comfort and fuel savings.

RESPECTING THE ENVIRONMENT

The E225BSR/235BSR are compliant with European Directives concerning electromagnetic compatibility and noise level. The emissions of the new Tier 3A HINO engine have been dramatically reduced and are, as shown below, lower than standard requirements.

CO: 3.50, HC + NOx: 4.00, Particulate: 0.20 (*)

...a real Environmentally Friendly machine.

(*) all data are expressed in g/kWh



ADVANCED TECHNOLOGIES & HYDRAULICS

A.E.P. - (Advanced Electronic Processor)

A.E.P. is a new Electronic Processor that interacts with the operator for selecting and monitoring all main working parameters, maintenance notifications, self diagnosis and operating data storage.

All this information is displayed in the new monitor, which features a larger back-lit, easier to read digital display and analogue gauges. Simply select the requested working mode and A.E.P. presets the hydraulic system to accomplish the job in the easiest and most productive way:

- **S mode** for normal working operations

- **H mode** when maximum power is required

Two additional modes are available for special applications and to operate tools like breakers and crushers:

- **A mode** adjusts the attachment circuit for tools which require two way flow.

A dedicated switch on the dashboard, enables the operator to select two pumps oil flow

- **B mode** for attachments featuring one way flow only.

Customers may choose to equip the machines with optional hammer & crusher and/or bucket rotation complete circuits.

Both in A and B working modes the operator, by using the buttons on the monitor, may adjust the flow by 10 l/min steps and the pressure by 10 bars steps to perfectly match the parameters of the attachment being used.

In addition, the operator can save to memory 9 combinations of flow and pressure in both A and B working modes, for a total of 18 combinations.

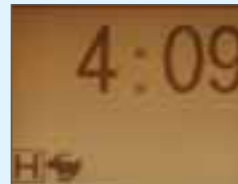
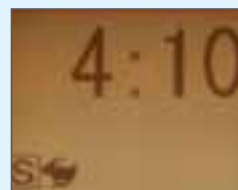

D.O.C. (Dipperstick Optimised Control)

The newly redesigned Control Valve features a second spool dedicated to dipperstick operation. The movement “dipper out” is now achieved with a double flow, i.e., using the flow of two pumps. The “dipper in” movement is even faster because of the double pump flow combined with the “Conflux”, or recirculation of unused oil which is diverted from return to tank.

A perfect combination of speed, efficiency, precision and increased production.

AUTO IDLING DEVICE

Engine speed is automatically reduced when the joysticks are left in neutral, helping effectively to save fuel, to reduce noise and pollution and to increase engine lifespan. When one or both joysticks are moved out of neutral the engine quickly returns to full speed.

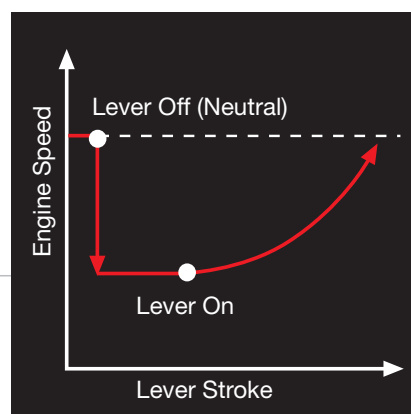

E225BSR/E235BSR



NEW CAB INTERIOR

The interior of the cab has been completely re-designed to maximise operator comfort and to enable optimum operator performance. All switches and controls are now ergonomically positioned on the right side, easy to find and to reach.

The radio and the new, more powerful and effective automatic air-conditioning system are standard equipment, creating an agreeable working atmosphere regardless of external weather conditions. At the same time, new interior design and materials create an elegant feeling. Rigid cab construction, combined with six silicon liquid filled viscous dampers, minimises vibrations.

Threaded holes, built into the cab structure, enable fast and easy attachment of optional FOPS structure and front guard, effectively contributing to operator safety.



NEW A. E. P. MONITOR

The newly designed A.E.P. Monitor, analogue gauges provide information at a glance, regardless of the operating environment.

The digital Display Screen has been enlarged to further enhance visibility.

Maintenance information is clearly displayed and the self-diagnostic function provides an early warning detection of malfunctions.

Details of any previous breakdown or malfunction are also stored.



NEW ONE-HAND WINDSCREEN OPENING

One-touch lock release simplifies opening and closing the front window, while a new mechanism makes it lighter.



INSTRUMENT LAYOUT

In-cab switches and controls have been moved to the right-hand side in an easy to reach and more ergonomic position, thus improving operator comfort and convenience.

OPERATOR SAFETY AND COMFORT



WIDER CAB ACCESS

The left console which incorporates the safety lock lever, now lifts-up 10 degrees more than in the previous model. A greater angle assures a wider cab access: an easier entry and exit for enhanced operator comfort.



NEW COMFORTABLE SEAT

New comfortable contoured seat which can be adjusted in all directions, together with or independently of side consoles. The armrests, integrated on side consoles, can be lifted/lowered into four different positions and inclined, enabling the operator to set the correct position for maximum convenience and comfort.

E225BSR/E235BSR

DESIGNED TO EFFECTIVELY CUT OPERATING COSTS

T CLEAN AND ACCESSIBLE LAYOUT

he new machines layout has been designed to make inspections, maintenance and servicing much easier and less time-consuming.

The engine oil filter, the fuel filter and the water separator are remote mounted and easy to reach from ground level. Both the fuel filter and the water separator, which removes contaminants and water, have an important function for engine performance and durability.

Cooling components (radiator, hydraulic oil cooler and intercooler) are now mounted in parallel, which means increased cooling efficiency for higher component reliability whilst being easier to check and clean.



T A MODERN DESIGN COMBINED WITH STATE OF-THE-ART TECHNOLOGY

he simplified layout of the New Holland E225BSR & E235BSR components, positioned under both the right and the left side panels, enables easy access from ground level and makes maintenance and inspections quicker and less expensive. Reduced maintenance and service costs to keep machines in perfect condition: low maintenance costs, high reliability and durability, minimised owning and operating costs for your improved profit.

EASY MAINTENANCE & SERVICING



VISUAL CHECKING & EASY CLEANING OF iNDR FILTERS

The iNDR filters are located in front of the cooling components (radiator, hydraulic oil cooler and intercooler) now mounted in parallel for improved cooling efficiency. The air goes directly from the intake duct through the iNDR stainless-steel filters which capture dust. The intake cleaned air, going through the cooling components, reduces clogging risks and minimises the cleaning intervals of maintenance routine. If they appear dirty during the start up inspection, they are easy to remove for cleaning without tools from ground level.



FUSES

The fuses are inside the cab, protected from dust and water and are easy to reach and control.

LONG LIFE HYDRAULIC OIL

The long-life hydraulic oil used by New Holland features excellent anti-emulsion characteristics as well as an optimised mix of anti-wear and anti-oxidants additives that **boost the service life to 5000 hours**, reducing the number of oil changes necessary and resulting in an impressive **reduction in operation costs and a higher respect for the environment**.

Air conditioning filter can easily be removed from under the seat without tools from ground level for easy cleaning.

INTERNAL CAB MAINTENANCE

- Air conditioning filter can easily be removed from under the seat without tools from ground level for easy cleaning.
- Detachable two-piece floormat with handles for easy removal. A floor drain is located under the mat to facilitate inside cab cleaning.



E225BSR

SPECIFICATIONS



ENGINE TIER 3A

Net flywheel power (ISO 14396/ECE R120) 118 kW/158 hp
 Rated rpm 2000
 Make and model HINO J05E-TA
 Type diesel, Common Rail, direct injection,
 turbocharged, intercooler

Displacement 5.1 l
 Number of cylinders 4
 Bore x Stroke 112 x 130 mm
 Maximum torque at 1600 rpm 572 Nm

Electronic engine rpm control dial type

“Auto-Idling” selector returns engine to minimum rpm when all controls are in neutral position.

The engine complies with 97/68/EC Standards TIER 3A



ELECTRICAL SYSTEM

Voltage 24 V
 Alternator 50 A
 Starter motor 5 kW
 Standard maintenance-free batteries 2
 Capacity 92 Ah



HYDRAULIC SYSTEM

Higher capacity pumps, to supply higher flow at lower rpm;
Redesigned Main Control Valve, with added 2nd dipper spool and new Fail Safe Functions;

H.A.O.A. (Hydrotronic Active Operation Aid) to get the best hydraulic output according to operator/ application demand;

E.S.S.C. (Engine Speed Sensing Control) device, for total installed hydraulic power exploitation;

D.O.C. (Dipper Optimised Control) thanks to the 2nd dedicated spool in the Control Valve and to the Conflux system;

C.P.B. (Continuous Power Boost) to allow the operator to use extra power when and how long it is needed;

A.E.P. (Advanced Electronic Processor) interacting with the operator for selecting and monitoring main working parameters, maintenance programmes, self diagnosis and operating data storage thanks to the new monitor with a larger digital display and analogical gauges;

Two working modes:

- **S** = for normal digging operation;
- **H** = when maximum power is required;

Two Attachments modes:

- **A** = for attachments which require double pump flow;
- **B** = for attachments, such as breaker, featuring one way flow only.

Standard double pump flow device and Diverter Valve automatically actuated while selecting A;

Pipe pressure discharge push button to facilitate tooling changeover without piping oil leakage;

Super Fine hydraulic filter (8 micron) to grant perfect oil filtration, contributing to increase oil change interval

“Power Boost” device

Main pumps:

Two variable delivery axial piston pumps

Pumps automatically revert to zero with controls in neutral

Maximum delivery 2 x 220 l/min

Pilot circuit gear type pump

Maximum delivery 20 l/min

Maximum operating pressure:

Equipment 34.3 MPa

Swing 29.0 MPa

Travel 34.3 MPa

Power Boost 37.8 MPa

Pilot circuit 5.0 MPa

Hydraulic cylinders	Number	Bore	Stroke
Lift	2	120 mm	1355 mm
Dipperstick	1	130 mm	1406 mm
Bucket	1	110 mm	1105 mm



TRANSMISSION

Type hydrostatic, two-speed

Travel motors 2, axial piston type, double displacement

Brakes oil bath disc type, automatically applied and hydraulically released

Final drives oil bath, planetary reduction

Gradeability (continuous) 70% (35°)

Travel speeds

Low from 0 to 3.6 km/h

High from 0 to 6.0 km/h

Drawbar pull 227 kN

“Automatic DownShift” device: to move travel motors to maximum displacement position with selector on “high speed” position when greater traction is required.



SWING

Swing motor axial piston type

Swing brake automatic disc type

Final drive oil bath, planetary reduction

Swing Ring oil bath type

Swing Speed 13.3 rpm



CAB AND CONTROLS

Transparent cab roof.

Standard automatic conditioning.

Controls piloted

Two cross pattern levers actuate all equipment movements and upperstructure swing

Two pedals with hand levers control all track movements, counter-rotation included.

A safety lever completely neutralizes the piloting circuit.



UNDERCARRIAGE

X-frame undercarriage design

Reinforced track chain with sealed bushings

Rollers:	STD	LC
Track rollers (each side)	7	8
Carrier rollers (each side)	2	2
Length of track on ground	3370 mm	3660 mm
Gauge	2200 mm	2390 mm
Shoes (mm)	600 - 700	600 - 700
	800	800



CAPACITIES

	litres
Engine	
Lube oil	20.5
Coolant	22.0
Fuel tank	300.0
Hydraulic system	230.0
Swing drive gear	3.0
Travel final drive (each)	5.3

ONE-PIECE BOOM

DIMENSIONS (mm) - OPERATING WEIGHT

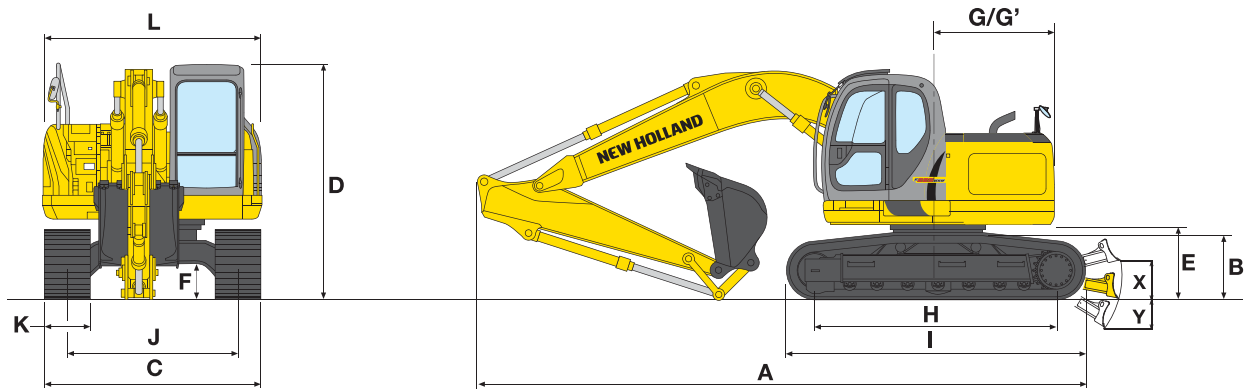

Versions	A	B	C	D	E	F	G/G'	H	I	J	L
E225BSR	8680	960	2800	3130	1020	455	1680/1845	3370	4170	2200	3000
E225BSR-LC	8830	960	2990	3130	1020	455	1680/1845	3660	4450	2390	3000

G' = Rear swing radius with additional (1.4 t) counterweight (optional)

		E225BSR			E225BSR - LC		
K - Shoe width	mm	600	700	800	600	700	800
C - maximum width	mm	2800	2900	3000	2990	3090	3190
Operating weight**	kg	22300	22700	23000	22700	23100	23400
Ground pressure	bar	0.50	0.44	0.39	0.47	0.41	0.36
Blade width	mm	2800	2990	2990	2990	-	-
Blade height	mm	685	680	680	680	-	-
Blade weight	kg	1650	1680	1680	1680	-	-
X - max lift	mm	540	540	540	540	-	-
Y - max dig.	mm	370	370	370	370	-	-

** Without blade (optional) and additional counterweight (optional)

DIGGING PERFORMANCE

ONE PIECE BOOM = 5620 mm

DIPPERSTICK	mm	2870
A	mm	9710
B	mm	9530
C	mm	6590
D	mm	10570
D'	mm	8150
E	mm	7700
F	mm	2970
G	mm	5960
H	mm	2290
I	mm	6380

BREAKOUT FORCE:		
Bucket	daN	12400
Dipperstick	daN	8800

"POWER BOOST" ON		
Bucket	daN	13600
Dipperstick	daN	9680

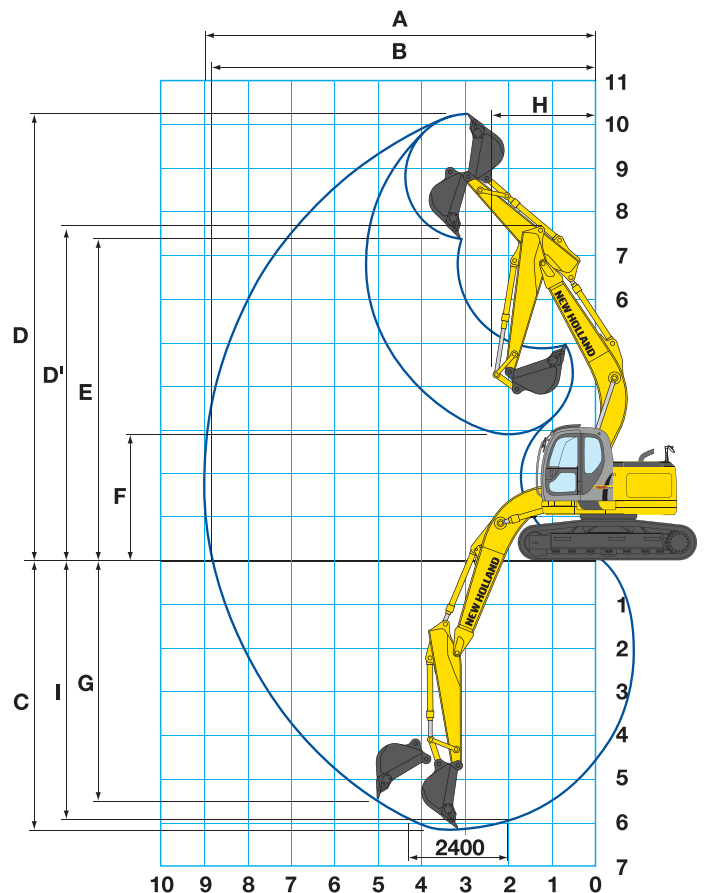

E225BSR

LIFTING CAPACITY

VALUES ARE EXPRESSED IN TONNES

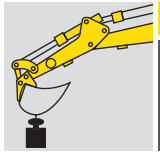

RADIUS OF LOAD

1.5 m		3.0 m		4.5 m		6.0 m		7.5 m		AT MAX. REACH		REACH m
FRONT	SIDE	FRONT	SIDE	FRONT	SIDE	FRONT	SIDE	FRONT	SIDE	FRONT	SIDE	

E225BSR ONE-PIECE BOOM - 2870 mm DIPPERSTICK

HEIGHT													
+7.5 m							2.52 *	2.52 *			2.17 *	2.17 *	6.15
+6.0 m							4.09 *	3.98			2.06 *	2.06 *	7.27
+4.5 m					6.25 *	6.24	5.36 *	3.80	3.36 *	2.51	2.08 *	2.08 *	7.95
+3.0 m			13.04 *	10.94	8.38 *	5.66	6.04	3.54	4.14	2.38	2.22 *	1.95	8.31
+1.5 m			7.64 *	7.64 *	9.22	5.10	5.74	3.27	4.00	2.25	2.48 *	1.83	8.39
0			8.07 *	8.07 *	8.81	4.75	5.52	3.07	3.88	2.15	2.94 *	1.85	8.19
-1.5 m	6.93 *	6.93 *	10.87 *	9.07	8.66	4.62	5.41	2.97	3.83	2.10	3.68	2.02	7.70
-3.0 m	10.10 *	10.10 *	12.82 *	9.23	8.70	4.65	5.42	2.98			4.44	2.45	6.84
-4.5 m			9.19 *	9.19 *	6.76 *	4.84					5.32 *	3.61	5.45

E225BSR-LC ONE-PIECE BOOM - 2870 mm DIPPERSTICK

HEIGHT													
+7.5 m							2.52 *	2.52 *			2.17 *	2.17 *	6.15
+6.0 m							4.09 *	4.05			2.06 *	2.06 *	7.27
+4.5 m					6.25 *	6.25 *	5.36 *	3.88	3.36 *	2.57	2.08 *	2.08 *	7.95
+3.0 m			13.04 *	11.14	8.38 *	5.77	6.50 *	3.61	4.71 *	2.44	2.22 *	2.00	8.31
+1.5 m			7.64 *	7.64 *	9.90 *	5.21	6.64	3.35	4.82	2.31	2.48 *	1.88	8.39
0			8.07 *	8.07 *	10.37	4.86	6.41	3.14	4.50	2.20	2.94 *	1.90	8.19
-1.5 m	6.93 *	6.93 *	10.87 *	9.27	10.21	4.73	6.29	3.05	4.44	2.16	3.78 *	2.07	7.70
-3.0 m	10.10 *	10.10 *	12.82 *	9.43	9.17 *	4.76	6.31	3.06			5.15	2.52	6.84
-4.5 m			9.19 *	9.19 *	6.76 *	4.95					5.32 *	3.70	5.45

E225BSR (*) ONE-PIECE BOOM - 2870 mm DIPPERSTICK

HEIGHT													
+7.5 m							2.52 *	2.52 *			2.17 *	2.17 *	6.15
+6.0 m							4.09 *	4.09 *			2.06 *	2.06 *	7.27
+4.5 m					8.25 *	8.25 *	5.36 *	4.44	3.36 *	3.00	2.08 *	2.08 *	7.95
+3.0 m			13.04 *	12.64	8.38 *	6.59	6.50 *	4.18	4.71 *	2.88	2.22 *	2.22 *	8.31
+1.5 m			7.64 *	7.64 *	9.90 *	6.03	6.58	3.91	4.62	2.74	2.48 *	2.26	8.39
0			8.07 *	8.07 *	10.10	5.58	6.36	3.71	4.51	2.63	2.94 *	2.29	8.19
-1.5 m	6.93 *	6.93 *	10.87 *	10.76	9.95	5.55	6.25	3.81	4.45	2.59	3.78 *	2.49	7.70
-3.0 m	10.10 *	10.10 *	12.82 *	10.93	9.17 *	5.58	6.25	3.62			5.14	3.00	6.84
-4.5 m			9.19 *	9.19 *	6.76 *	5.77					5.32 *	4.33	5.45

E225BSR-LC (*) ONE-PIECE BOOM - 2870 mm DIPPERSTICK

HEIGHT													
+7.5 m							2.52 *	2.52 *			2.17 *	2.17 *	6.15
+6.0 m							4.09 *	4.09 *			2.06 *	2.06 *	7.27
+4.5 m					6.25 *	6.25 *	5.36 *	4.52	3.36 *	3.05	2.08 *	2.08 *	7.95
+3.0 m			13.04 *	12.84	8.38 *	6.70	6.50 *	4.25	4.71 *	2.93	2.22 *	2.22 *	8.31
+1.5 m			7.84 *	7.84 *	9.90 *	5.14	7.24 *	3.99	5.28	2.80	2.48 *	2.31	8.39
0			8.07 *	8.07 *	10.59 *	5.79	7.31	3.79	5.16	2.69	2.94 *	2.34	8.19
-1.5 m	6.93 *	6.93 *	10.87 *	10.87 *	10.33 *	5.66	7.20	3.69	5.11	2.85	3.78 *	2.54	7.70
-3.0 m	10.10 *	10.10 *	12.82 *	11.13	9.17 *	5.69	6.73 *	3.70			5.55 *	3.06	6.84
-4.5 m			9.19 *	9.19 *	6.76 *	5.88					5.32 *	4.42	5.45

The table values refer to ISO 10567 for excavator equipped with bucket. The indicated load is no more than 87% of hydraulic system lift capacity or 75% of static tipping load. Values marked with an asterisk are limited by the hydraulic system.

* with 1.4 tonnes additional counterweight

E235BSR

SPECIFICATIONS



ENGINE TIER 3A

Net flywheel power (ISO 14396/ECE R120)118 kW/158 hp
 Rated rpm2000
 Make and model.....HINO J05E-TA
 Typediesel, Common Rail, direct injection, turbocharged, intercooler
 Displacement.....5.1 l
 Number of cylinders4
 Bore x Stroke.....112 x 130 mm
 Maximum torque at 1600 rpm.....572 Nm
Electronic engine rpm control dial type
“Auto-Idling” selector returns engine to minimum rpm when all controls are in neutral position.
The engine complies with 97/68/EC Standards TIER 3A



ELECTRICAL SYSTEM

Voltage.....24 V
 Alternator50 A
 Starter motor.....5 kW
 Standard maintenance-free batteries2
 Capacity.....92 Ah



HYDRAULIC SYSTEM

Higher capacity pumps, to supply higher flow at lower rpm;
Redesigned Main Control Valve, with added 2nd dipper spool and new Fail Safe Functions;
H.A.O.A. (Hydrotronic Active Operation Aid) to get the best hydraulic output according to operator/ application demand;
E.S.S.C. (Engine Speed Sensing Control) device, for total installed hydraulic power exploitation;
D.O.C. (Dipper Optimised Control) thanks to the 2nd dedicated spool in the Control Valve and to the Conflux system;
C.P.B. (Continuous Power Boost) to allow the operator to use extra power when and how long it is needed;
A.E.P. (Advanced Electronic Processor) interacting with the operator for selecting and monitoring main working parameters, maintenance programmes, self diagnosis and operating data storage thanks to the new monitor with a larger digital display and analogical gauges;

Two working modes:

- **S** = for normal digging operation;
- **H** = when maximum power is required;

Two Attachments modes:

- **A** = for attachments which require double pump flow;
- **B** = for attachments, such as breaker, featuring one way flow only.

Standard double pump flow device and Diverter Valve automatically actuated while selecting A;

Pipe pressure discharge push button to facilitate tooling changeover without piping oil leakage;

Super Fine hydraulic filter (8 micron) to grant perfect oil filtration, contributing to increase oil change interval

“Power Boost” device

Main pumps:

Two variable delivery axial piston pumps

Pumps automatically revert to zero with controls in neutral

Maximum delivery.....2 x 220 l/min

Pilot circuit gear type pump

Maximum delivery20 l/min

Maximum operating pressure:

Equipment.....34.3 MPa

Swing.....28.5 MPa

Travel.....34.3 MPa

Power Boost37.8 MPa

Pilot circuit.....5.0 MPa

Hydraulic cylinders	Number	Bore	Stroke
Lift	2	125 mm	1320 mm
Dipperstick	1	135 mm	1558 mm
Bucket	1	120 mm	1080 mm
Positioning (only triple articulation)		150 mm	1193 mm



TRANSMISSION

Typehydrostatic, two-speed
 Travel motors.....2, axial piston type, double displacement
 Brakesoil bath disc type, automatically applied and hydraulically released
 Final drivesoil bath, planetary reduction
 Gradeability (continuous)70% (35°)
 Travel speeds
 Lowfrom 0 to 3.4 km/h
 Highfrom 0 to 5.5 km/h
 Drawbar pull.....243 kN
“Automatic DownShift” device: to move travel motors to maximum displacement position with selector on “high speed” position when greater traction is required.



SWING

Swing motoraxial piston type
 Swing brakeautomatic disc type
 Final driveoil bath, planetary reduction
 Swing Ringoil bath type
 Swing Speed.....12.0 rpm



CAB AND CONTROLS

Transparent cab roof.
 Standard automatic conditioning.
 Controlspiloted
 Two cross pattern levers actuate all equipment movements and upperstructure swing
 Two pedals with hand levers control all track movements, counter-rotation included.
 A safety lever completely neutralizes the piloting circuit.



UNDERCARRIAGE

X-frame undercarriage design
 Reinforced track chain with sealed bushings

Rollers:	NLC	LC
Track rollers (each side)	9	9
Carrier rollers (each side)	2	2
Length of track on ground	3850 mm	3850 mm
Gauge	2390 mm	2590 mm
Shoes (mm)	600 - 700	600 - 700
	800	800



CAPACITIES

	litres
Engine	
Lube oil20.5	
Coolant22.0	
Fuel tank330.0	
Hydraulic system230.0	
Swing drive gear7.0	
Travel final drive (each)4.5	

E235BSR

ONE-PIECE BOOM

DIMENSIONS (mm) - OPERATING WEIGHT

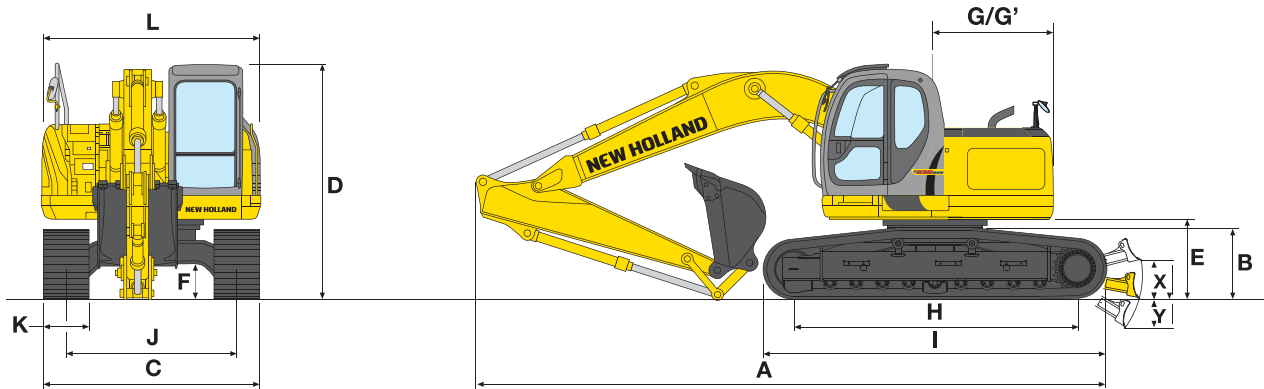

Versions	A	B	C	D	E	F	G/G'	H	I	J	L
E235BSR-NLC	8980	960	2990	3160	1050	455	1730/1895	3850	4640	2390	3000
E235BSR-LC	8980	960	3190	3160	1050	455	1730/1895	3850	4640	2590	3000

G'= Rear swing radius with additional (1.4 t) counterweight (optional)

		E235BSR - NLC			E235BSR - LC		
K - Shoe width	mm	600	700	800	600	700	800
C - maximum width	mm	2990	3090	3190	3190	3290	3390
Operating weight (**)	kg	24600	24600	25200	24700	25000	25300
Ground pressure	bar	0.48	0.42	0.37	0.48	0.42	0.37
Blade width	mm	2990	-	-	-	-	-
Blade height	mm	685	-	-	-	-	-
Blade weight	kg	1680	-	-	-	-	-
X - max lift	mm	560	-	-	-	-	-
Y - max dig.	mm	350	-	-	-	-	-

** Without blade (optional) and additional counterweight (optional)

DIGGING PERFORMANCE

ONE PIECE BOOM = 5650 mm

DIPPERSTICK	mm	2940	3330
A	mm	9850	10240
B	mm	9680	10070
C	mm	6650	7040
D	mm	11210	11550
D'	mm	8400	8420
E	mm	8330	8670
F	mm	3140	2870
G	mm	6050	6660
H	mm	1930	2370
I	mm	6470	6880

BREAKOUT FORCE:			
Bucket	daN	14300	14300
Dipperstick	daN	10200	9680

"POWER BOOST" ON			
Bucket	daN	15700	15700
Dipperstick	daN	11200	10600

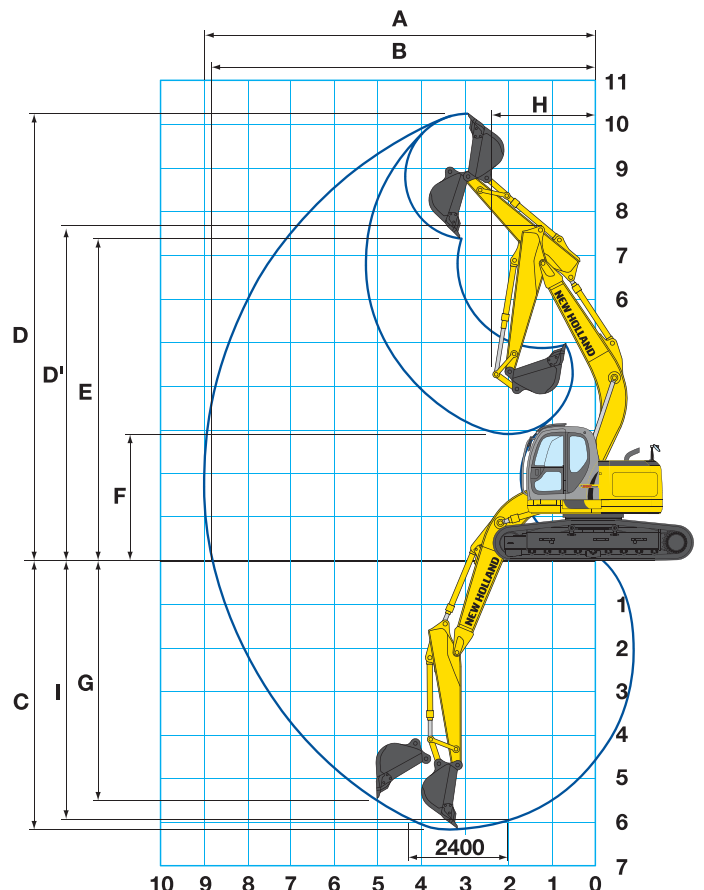

TRIPLE ARTICULATION

DIMENSIONS (mm) - OPERATING WEIGHT

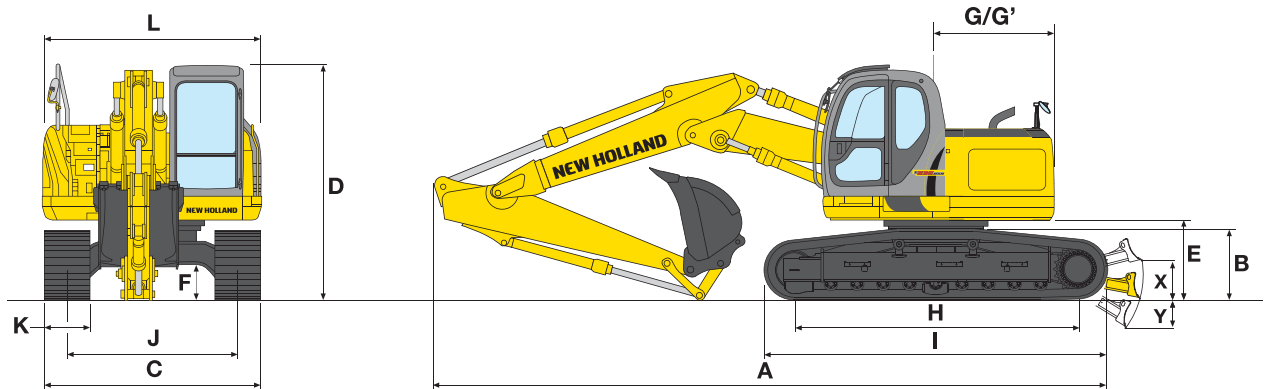

Versions	A	B	C	D	E	F	G/G'	H	I	J	L
E235BSR-NLC	9520	960	2990	3160	1050	455	1730/1895	3850	4640	2390	3000
E235BSR-LC	8980	960	3190	3160	1050	455	1730/1895	3850	4640	2590	3000

G' = Rear swing radius with additional (1.4 t) counterweight (optional)

		E235BSR - NLC			E235BSR - LC		
K - Shoe width	mm	600	700	800	600	700	800
C - maximum width	mm	2990	3090	3190	3190	3290	3390
Operating weight (**)	kg	25700	26000	26300	25800	26100	26400
Ground pressure	bar	0.51	0.44	0.39	0.51	0.44	0.39
Blade width	mm	2990	-	-	-	-	-
Blade height	mm	685	-	-	-	-	-
Blade weight	kg	1680	-	-	-	-	-
X - max lift	mm	560	-	-	-	-	-
Y - max dig.	mm	350	-	-	-	-	-

** Without blade (optional) and additional counterweight (optional)

DIGGING PERFORMANCE

TRIPLE ARTICULATION
max extension = 6230 mm
min extension = 4540 mm

DIPPERSTICK	mm	2940	3330
A	mm	10360	10750
B	mm	10200	10590
C	mm	6990	7380
D	mm	11950	12290
D'	mm	9070	9100
E	mm	9030	9400
F	mm	1450	1180
G	mm	6100	6710
H	mm	1440	1880
I	mm	6890	7300

BREAKOUT FORCE:			
Bucket	daN	14300	14300
Dipperstick	daN	10200	9680

"POWER BOOST" ON			
Bucket	daN	15700	15700
Dipperstick	daN	11200	10600

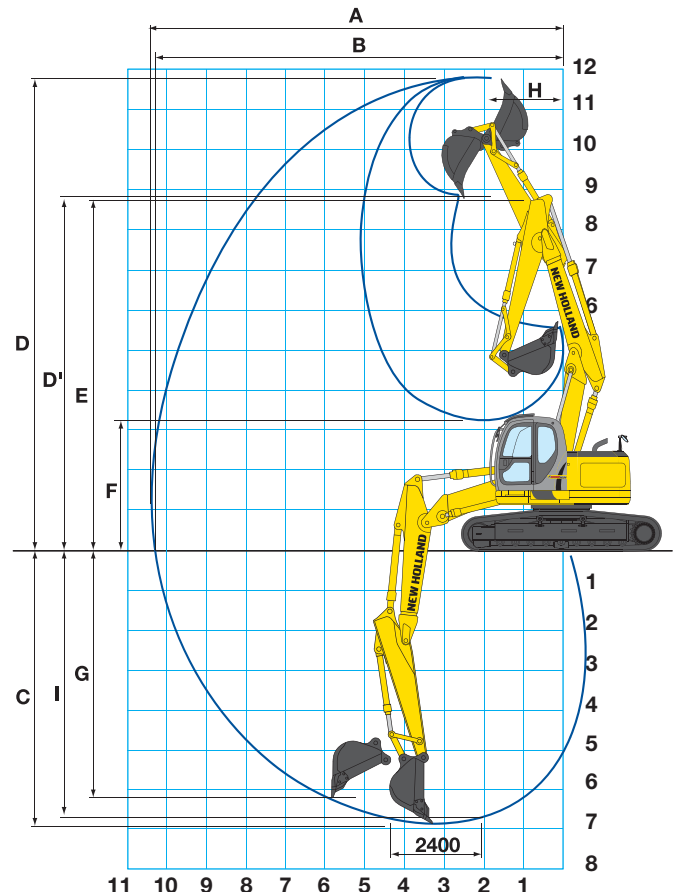

E235BSR

LIFTING CAPACITY

VALUES ARE EXPRESSED IN TONNES

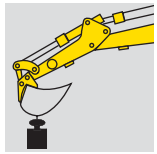

RADIUS OF LOAD

1.5 m		3.0 m		4.5 m		6.0 m		7.5 m		AT MAX. REACH		REACH m
FRONT	SIDE	FRONT	SIDE	FRONT	SIDE	FRONT	SIDE	FRONT	SIDE	FRONT	SIDE	

E235BSR-NLC ONE-PIECE BOOM - 2940 mm DIPPERSTICK

HEIGHT														
+4.5 m				8.36*	8.36*	7.24*	7.24*	6.08*	4.55	4.86*	3.03	3.02*	2.63	8.03
+3.0 m				13.74*	13.33	8.81*	6.78	8.77*	4.24	5.45	2.88	3.17*	2.33	8.38
+1.5 m				7.95*	7.95*	10.13*	6.14	7.40*	3.99	5.27	2.73	3.48*	2.21	8.45
0				8.83*	8.83*	10.56*	5.75	7.34	3.71	5.14	2.61	4.03*	2.23	8.25
-1.5 m	7.67*	7.67*		12.32*	11.22	10.03*	5.61	7.22	3.60	5.08	2.56	4.83	2.43	7.76
-3.0 m	11.64*	11.64*		11.71*	11.41	8.59*	5.65	6.31*	3.62			5.03	2.94	6.91
-4.5 m				7.80*	7.80*	5.90*	5.87					4.44*	4.28	5.54

E235BSR-LC ONE-PIECE BOOM - 2940 mm DIPPERSTICK

HEIGHT														
+6.0 m						6.03*	6.03*	5.61*	5.26			3.01*	3.01*	7.36
+4.5 m				8.36*	8.36*	7.24*	7.24*	6.08*	5.04	4.86*	3.38	3.02*	2.95	8.03
+3.0 m				13.74*	13.74*	8.81*	7.58	6.77*	4.73	5.46*	3.23	3.17*	2.63	8.38
+1.5 m				7.95*	7.95*	10.13*	6.92	7.40*	4.42	5.29*	3.07	3.48*	2.50	8.45
0				8.83*	8.83*	10.56*	6.52	7.36*	4.19	5.15	2.95	4.03*	2.53	8.25
-1.5 m	7.67*	7.67*		12.32*	12.32*	10.03*	6.38	7.24*	4.07	5.10*	2.90	4.84	2.76	7.76
-3.0 m	11.64*	11.64*		11.71*	11.71*	8.59*	6.42	6.31*	4.09			5.03*	3.33	6.91
-4.5 m				7.80*	7.80*	5.90*	5.90*					4.44*	4.44*	5.54

E235BSR-NLC ONE-PIECE BOOM - 3330 mm DIPPERSTICK

HEIGHT														
+6.0 m						5.16*	5.16*	5.20*	4.83	3.77*	3.14	2.86*	2.86*	7.82
+4.5 m				5.80*	5.80*	6.39*	6.39*	5.74*	4.60	5.09*	3.05	2.85*	2.38	8.46
+3.0 m				12.51*	12.51*	8.30*	6.90	8.47*	4.28	5.45*	2.89	2.96*	2.12	8.79
+1.5 m				9.75*	9.75*	9.78*	6.21	7.18*	3.95	5.27	2.72	3.21*	2.00	8.86
0				8.82*	8.82*	10.46*	5.75	7.33	3.69	5.11	2.58	3.64*	2.02	8.66
-1.5 m	6.76*	6.76*		11.52*	11.07	10.18*	5.55	7.17	3.55	5.03	2.50	4.39	2.18	8.20
-3.0 m	10.36*	10.36*		12.61*	11.21	8.99*	5.54	6.60*	3.53			4.76*	2.58	7.40
-4.5 m	12.63*	12.63*		9.05*	9.05*	6.68*	5.72	4.57*	3.68			4.34*	3.56	6.14

E235BSR-LC ONE-PIECE BOOM - 3330 mm DIPPERSTICK

HEIGHT														
+6.0 m						5.16*	5.16*	5.20*	5.20*	3.77*	3.50	2.86*	2.86*	7.82
+4.5 m				5.80*	5.80*	6.39*	6.39*	5.74*	5.10	5.09*	3.40	2.85*	2.68	8.46
+3.0 m				12.51*	12.51*	8.30*	7.71	6.47*	4.77	5.45*	3.24	2.96*	2.40	8.79
+1.5 m				9.75*	9.75*	9.78*	6.99	7.18*	4.43	5.28	3.07	3.21*	2.28	8.86
0				8.82*	8.82*	10.46*	6.52	7.35	4.17	5.13	2.92	3.64*	2.30	8.66
-1.5 m	6.76*	6.76*		11.52*	11.52*	10.18*	6.31	7.19	4.02	5.04	2.85	4.40*	2.48	8.20
-3.0 m	10.36*	10.36*		12.61*	12.61*	8.99*	6.31	6.80*	4.01			4.76*	2.93	7.40
-4.5 m	12.63*	12.63*		9.05*	9.05*	6.68*	6.49	4.57*	4.16			4.34*	4.02	6.14

E235BSR-NLC (*) ONE-PIECE BOOM - 3330 mm DIPPERSTICK

HEIGHT														
+6.0 m						5.16*	5.16*	5.20*	5.20*	3.77*	3.65	2.86*	2.86*	7.82
+4.5 m				5.80*	5.80*	6.39*	6.39*	5.74*	5.27	5.09*	3.56	2.85*	2.82	8.46
+3.0 m				12.51*	12.51*	8.30*	7.88	6.47*	4.95	5.45*	3.40	2.96*	2.54	8.79
+1.5 m				9.75*	9.75*	9.78*	7.18	7.18*	4.61	5.76*	3.23	3.21*	2.42	8.86
0				8.82*	8.82*	10.46*	6.72	7.57*	4.36	5.80	3.08	3.64*	2.44	8.66
-1.5 m	6.76*	6.76*		11.52*	11.52*	10.18*	6.52	7.44*	4.21	5.63*	3.01	4.40*	2.63	8.20
-3.0 m	10.36*	10.36*		12.61*	12.61*	8.99*	6.52	6.60*	4.20			4.76*	3.09	7.40
-4.5 m	12.63*	12.63*		9.05*	9.05*	6.68*	6.68*	4.57*	4.34			4.34*	4.20	6.14

E235BSR-LC (*) ONE-PIECE BOOM - 3330 mm DIPPERSTICK

HEIGHT														
+6.0 m						5.16*	5.16*	5.20*	5.20*	3.77*	3.77*	2.86*	2.86*	7.82
+4.5 m				5.80*	5.80*	6.39*	6.39*	5.74*	5.74*	5.09*	3.93	2.85*	2.85*	8.46
+3.0 m				12.51*	12.51*	8.30*	8.30*	6.47*	5.48	5.45*	3.77	2.96*	2.84	8.79
+1.5 m				9.75*	9.75*	9.78*	8.03	7.18*	5.14	5.76*	3.60	3.21*	2.71	8.86
0				8.82*	8.82*	10.46*	7.56	7.57*	4.87	5.81	3.45	3.64*	2.74	8.66
-1.5 m	6.76*	6.76*		11.52*	11.52*	10.18*	7.35	7.44*	4.73	5.63*	3.38	4.40*	2.96	8.20
-3.0 m	10.36*	10.36*		12.61*	12.61*	8.99*	7.35	6.60*	4.71			4.76*	3.47	7.40
-4.5 m	12.63*	12.63*		9.05*	9.05*	6.68*	6.68*	4.57*	4.57*			4.34*	4.34*	6.14

The table values refer to ISO 10567 for excavator equipped with bucket. The indicated load is no more than 87% of hydraulic system lift capacity or 75% of static tipping load. Values marked with an asterisk are limited by the hydraulic system.

LIFTING CAPACITY

VALUES ARE EXPRESSED IN TONNES

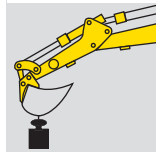

RADIUS OF LOAD

1.5 m		3.0 m		4.5 m		6.0 m		7.5 m		AT MAX. REACH		REACH m
FRONT	SIDE	FRONT	SIDE	FRONT	SIDE	FRONT	SIDE	FRONT	SIDE	FRONT	SIDE	

E235BSR-NLC TRIPLE ARTICULATION - 2940 mm DIPPERSTICK

HEIGHT	1.5 m		3.0 m		4.5 m		6.0 m		7.5 m		AT MAX. REACH		REACH m
	FRONT	SIDE	FRONT	SIDE	FRONT	SIDE	FRONT	SIDE	FRONT	SIDE	FRONT	SIDE	
+4.5 m	26.20*	26.20*	12.24*	12.24*	8.42*	7.45	4.45*	4.45*	4.96*	3.00	3.10	2.29	8.53
+3.0 m			7.39*	7.39*	5.75*	5.75*	4.02*	4.02*	5.17*	2.79	3.30	2.00	8.86
+1.5 m			12.08*	10.35	7.79*	5.67	5.98*	3.70	5.18	2.57	3.66	1.85	8.93
0	11.79*	11.79*	6.25*	6.25*	9.46*	5.23	7.05*	3.40	4.99	2.39	3.92	1.84	8.74
-1.5 m	14.20*	14.20*	9.84*	9.84*	8.53*	5.08	6.52*	3.25	4.88	2.30	4.14*	1.97	8.27
-3.0 m	15.38*	15.38*	7.80*	7.80*	6.70*	5.11	5.22*	3.24			3.69*	2.32	7.48
-4.5 m	21.04*	21.04*	4.12*	4.12*	4.03*	4.03*	2.97*	2.97*			2.72*	2.72*	6.24

E235BSR-LC TRIPLE ARTICULATION - 2940 mm DIPPERSTICK

HEIGHT	1.5 m		3.0 m		4.5 m		6.0 m		7.5 m		AT MAX. REACH		REACH m
	FRONT	SIDE	FRONT	SIDE	FRONT	SIDE	FRONT	SIDE	FRONT	SIDE	FRONT	SIDE	
+6.0 m			6.19*	6.19*	5.61*	5.61*	4.75*	4.75*	4.25*	3.52	3.03	3.03	7.90
+4.5 m	26.20*	26.20*	12.24*	12.24*	8.42*	8.30	4.45*	4.45*	4.96*	3.37	3.10	2.59	8.53
+3.0 m			7.39*	7.39*	5.75*	5.75*	4.02*	4.02*	5.17*	3.15	3.30	2.28	8.86
+1.5 m			12.08*	12.08*	7.79*	6.47	5.98*	4.19	5.20	2.92	3.66	2.13	8.93
0	11.79*	11.79*	6.25*	6.25*	9.46*	6.01	7.05*	3.89	5.00	2.74	3.92	2.12	8.74
-1.5 m	14.20*	14.20*	9.84*	9.84*	8.53*	5.85	6.52*	3.74	4.90	2.65	4.14*	2.27	8.27
-3.0 m	15.38*	15.38*	7.80*	7.80*	6.70*	5.89	5.22*	3.73			3.69*	2.67	7.48
-4.5 m	21.04*	21.04*	4.12*	4.12*	4.03*	4.03*	2.97*	2.97*			2.72*	2.72*	6.24

E235BSR-NLC TRIPLE ARTICULATION - 3330 mm DIPPERSTICK

HEIGHT	1.5 m		3.0 m		4.5 m		6.0 m		7.5 m		AT MAX. REACH		REACH m
	FRONT	SIDE	FRONT	SIDE	FRONT	SIDE	FRONT	SIDE	FRONT	SIDE	FRONT	SIDE	
+6.0 m					5.52*	5.52*	4.04*	4.04*	4.53*	3.16	2.85	2.47	8.35
+4.5 m	9.92*	9.92*	8.95*	8.95*	7.92*	7.59	3.75*	3.75*	4.46*	2.99	2.89	2.02	8.95
+3.0 m	31.47*	31.47*	14.43*	12.68*	9.14*	6.59	4.72*	4.11	4.56*	2.75	3.04	1.76	9.26
+1.5 m			4.95*	4.95*	7.09*	5.68	5.74*	3.65	5.06*	2.50	3.32	1.62	9.33
0	10.19*	10.19*	6.29*	6.29*	8.93*	5.13	6.71*	3.31	4.90	2.30	3.54	1.60	9.14
-1.5 m	6.01*	6.01*	9.14*	9.14*	8.74*	4.90	6.57*	3.12	4.76	2.18	3.77	1.69	8.70
-3.0 m	8.82*	8.82*	8.79*	8.79*	7.09*	4.89	5.45*	3.08	3.96*	2.16	3.46*	1.98	7.96
-4.5 m	24.83*	24.83*	5.24*	5.24*	4.66*	4.66*	3.52*	3.19			2.71*	2.64	6.80

E235BSR-LC TRIPLE ARTICULATION - 3330 mm DIPPERSTICK

HEIGHT	1.5 m		3.0 m		4.5 m		6.0 m		7.5 m		AT MAX. REACH		REACH m
	FRONT	SIDE	FRONT	SIDE	FRONT	SIDE	FRONT	SIDE	FRONT	SIDE	FRONT	SIDE	
+6.0 m					5.52*	5.52*	4.04*	4.04*	4.53*	3.53	2.85	2.78	8.35
+4.5 m	9.92*	9.92*	8.95*	8.95*	7.92*	7.92*	3.75*	3.75*	4.46*	3.35	2.89	2.30	8.95
+3.0 m	31.47*	31.47*	14.43*	14.43	9.14*	7.42	4.72*	4.61	4.56*	3.11	3.04	2.02	9.26
+1.5 m			4.95*	4.95*	7.09*	6.47	5.74*	4.15	5.06*	2.86	3.32	1.89	9.33
0	10.19*	10.19*	6.29*	6.29*	8.93*	5.91	6.71*	3.80	4.92	2.65	3.55	1.87	9.14
-1.5 m	6.01*	6.01*	9.14*	9.14*	8.74*	5.68	6.57*	3.61	4.78	2.53	3.79	1.98	8.70
-3.0 m	8.82*	8.82*	8.79*	8.79*	7.09*	5.67	5.45*	3.56	3.96*	2.51	3.46*	2.30	7.96
-4.5 m	24.83*	24.83*	5.24*	5.24*	4.66*	4.66*	3.52*	3.52*			2.71*	2.71*	6.80

E235BSR-NLC (*) TRIPLE ARTICULATION - 3330 mm DIPPERSTICK

HEIGHT	1.5 m		3.0 m		4.5 m		6.0 m		7.5 m		AT MAX. REACH		REACH m
	FRONT	SIDE	FRONT	SIDE	FRONT	SIDE	FRONT	SIDE	FRONT	SIDE	FRONT	SIDE	
+6.0 m					5.52*	5.52*	4.04*	4.04*	4.53*	3.67	2.85	2.85	8.35
+4.5 m	9.92*	9.92*	8.95*	8.95*	7.92*	7.92*	3.75*	3.75*	4.46*	3.50	2.89	2.43	8.95
+3.0 m	31.47*	31.47*	14.43*	14.43*	9.14*	7.57	4.72*	4.72*	4.56*	3.26	3.04	2.15	9.26
+1.5 m			4.95*	4.95*	7.09*	6.65	5.74*	4.32	5.06*	3.01	3.32	2.01	9.33
0	10.19*	10.19*	6.29*	6.29*	8.93*	6.10	6.71*	3.98	5.45	2.81	3.80	2.00	9.14
-1.5 m	6.01*	6.01*	9.14*	9.14*	8.74*	5.88	6.57*	3.79	4.99*	2.68	3.84*	2.12	8.70
-3.0 m	8.82*	8.82*	8.79*	8.79*	7.09*	5.87	5.45*	3.74	3.96*	2.67	3.46*	2.45	7.96
-4.5 m	24.83*	24.83*	5.24*	5.24*	4.66*	4.66*	3.52*	3.52			2.71*	2.71*	6.80

E235BSR-LC (*) TRIPLE ARTICULATION - 3330 mm DIPPERSTICK

HEIGHT	1.5 m		3.0 m		4.5 m		6.0 m		7.5 m		AT MAX. REACH		REACH m
	FRONT	SIDE	FRONT	SIDE	FRONT	SIDE	FRONT	SIDE	FRONT	SIDE	FRONT	SIDE	
+6.0 m					5.52*	5.52*	4.04*	4.04*	4.53*	4.06	2.85	2.85	8.35
+4.5 m	9.92*	9.92*	8.95*	8.95*	7.92*	7.92*	3.75*	3.75*	4.46*	3.88	2.89	2.73	8.95
+3.0 m	31.47*	31.47*	14.43*	14.43*	9.14*	8.46	4.72*	4.72*	4.56*	3.64	3.04	2.43	9.26
+1.5 m			4.95*	4.95*	7.09*	7.09*	5.74*	4.85	5.06*	3.39	3.32	2.29	9.33
0	10.19*	10.19*	6.29*	6.29*	8.93*	6.95	6.71*	4.50	5.45*	3.19	3.80	2.29	9.14
-1.5 m	6.01*	6.01*	9.14*	9.14*	8.74*	6.72	6.57*	4.31	4.99*	3.06	3.84*	2.43	8.70
-3.0 m	8.82*	8.82*	8.79*	8.79*	7.09*	6.71	5.45*	4.26	3.96*	3.04	3.46*	2.79	7.96
-4.5 m	24.83*	24.83*	5.24*	5.24*	4.66*	4.66*	3.52*	3.52*			2.71*	2.71*	6.80

The table values refer to ISO 10567 for excavator equipped with bucket. The indicated load is no more than 87% of hydraulic system lift capacity or 75% of static tipping load. Values marked with an asterisk are limited by the hydraulic system.

* with 1.4 tonnes additional counterweight

NEW HOLLAND. THE POWER OF A GLOBAL BRAND

New Holland is a global brand with a key position in the Construction Equipment business. It supplies a complete range of 13 product lines and 80 basic models split into Compact line and Heavy line. It operates in all the main markets, such as Europe, North and Latin America, Africa, Asia and Middle East with the same technology and under the same logo and brand. It manufactures durable, safe and productive machines aimed at supporting customers in developing their own business. Dealers are company partners. They play an important role to support the brand in their territories through intense professional relationship with Customers. New Holland is reinforced by its global alliance with Kobelco: world leader in hydraulic excavator technology.



AT YOUR OWN DEALERSHIP

The information contained in this brochure is intended to be a general nature only. The NEW HOLLAND KOBELCO CONSTRUCTION MACHINERY S.p.A. company may at any time and from time to time, for technical or other necessary reasons, modify any of the details or specifications of the product described in this brochure. Illustrations do not necessarily show products in standard conditions. The dimensions, weights and capacities shown herein, as well as any conversion data used, are approximate only and are subject to variations within normal manufacturing techniques.

Published by NEW HOLLAND KOBELCO CONSTRUCTION MACHINERY S.p.A.
Printed in Italy - LEADER Firenze - Cod. 73301 433GB - Printed 07/08

Printed on recycled paper
CoC-FSC 000010 CQ Mixed sources



ELEMENTAL
CHLORINE
FREE
GUARANTEED

FIAT
GROUP



BUILT AROUND YOU



www.newholland.com